

NIKON

F2AS

Photomic

INSTRUCTION MANUAL

WWW.LENSIN

NOMENCLATURE

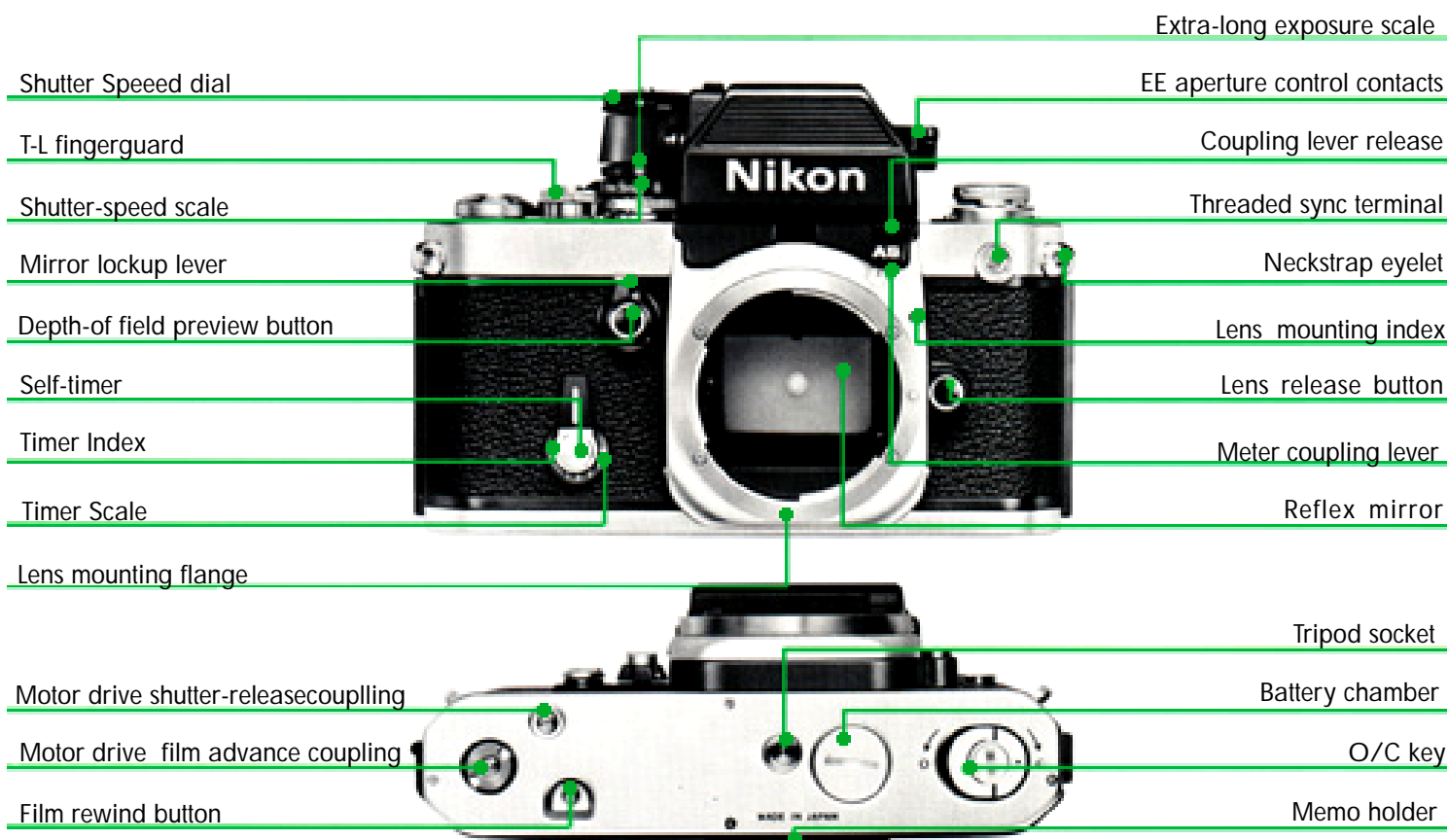

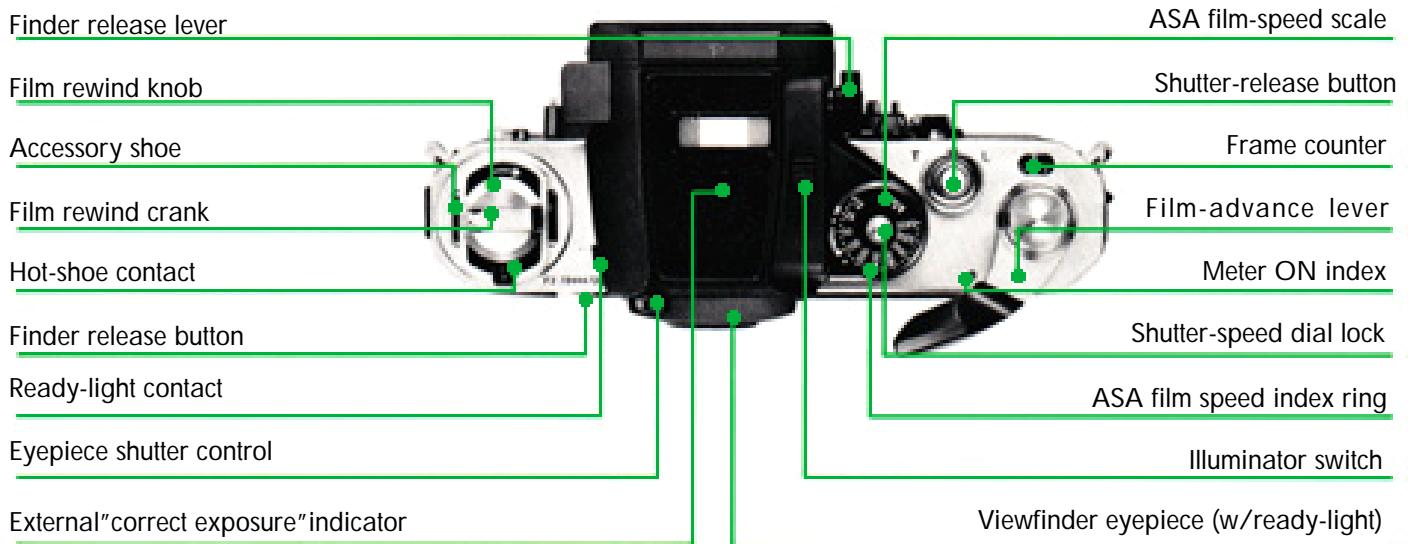
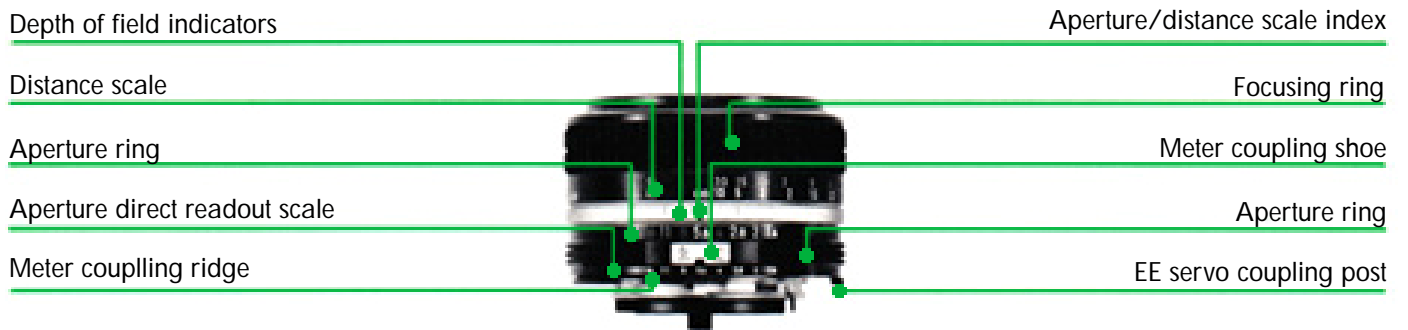

WWW.LENSINC.NET

CONTENTS

Foreword	5	Metering range	24
Preparation for use	6	Extreme low-light metering.....	25
Installing the batteries	6	Time exposure.....	25
Checking the batteries	6	Eyepiece shutter operation.....	26
Loading the film.....	7	High-contrast lighting.....	26
Prior to shooting.....	8	Stop-down exposure measurement.....	28
Memo holder.....	9	Exposure compensation adjustment	30
Setting the film speed.....	9	Adjustment for focusing screens.....	30
Operation of camera controls	10	Adjustment for film compensation.....	32
Setting the shutter speed.....	10	Multiple exposures	33
Setting the aperture.....	10	Mirror lockup	33
Film-advance lever.....	11	Flash synchronization	34
Frame counter.....	11	Ready-light	35
Self-timer.....	12	Finder illuminator.....	35
Unloading film	13	Tips on camera care	36
Holding the camera	14	Changing the lens	38
Shutter release operation	15	Coupling lever lock/release operation.....	39
Operation via cable release.....	15	Changing the view finder	40
Focusing	16	Changing the focusing screen	41
Infrared photography.....	18	Focusing screen selector guide.....	42
Film-planeindicator.....	18	Focusing screen selector chart.....	43
Depth of field	19	Accessories	44
Depth-of-field preview lever.....	19	Features/Specifications	46
Depth-of-field indicators.....	20		
Exposure measurement	22		
Determining degree of exposure.....	22		
Exposure control.....	24		

FOREWORD

The Nikon F2AS Photomic camera offers the serious photographer the ultimate in quality, performance, convenience and versatility. At the same time, it is engineered to take the guesswork out of photography with automatic features anyone can learn to use in minutes. To get the most out of your Nikon F2AS Photomic, study the instructions carefully and practice using the controls before you load any film in the camera. Keep this book, let handy for ready reference until you have mastered its basics, and follow the suggestions for camera care given on page 36. The few moments you spend familiarizing yourself with the camera will guarantee you the best results and increase your picture-taking enjoyment many times over.

PREPARATION FOR USE

Installing the Batteries

The exposure meter in the Photomic finder is powered by two high-performance silver-oxide batteries mounted in the battery chamber in the baseplate of the camera. To install the batteries, first remove the battery chamber cover (turn it 90° counterclockwise using a coin or similar object); then, place two 1.5V silver-oxide (buttoncell type) batteries in the chamber, making sure that the plus (+) side of each unit faces out. After inserting and properly seating the batteries, replace the cover and lock it to secure the assembly.

Note: Remove the batteries when the camera is not to be used for a long period; this will prevent leakage within the camera. Also, keep the camera as warm as possible when operating under cold-weather conditions; otherwise, the batteries may fail to function. (See “Tips on Camera Care” on page 36 for additional information.)

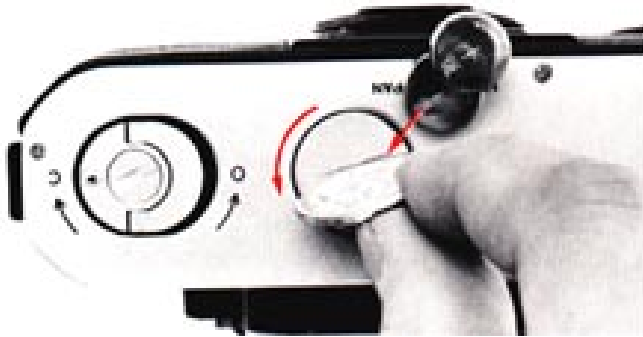

Checking the Batteries

The camera's film-advance lever serves as the ON-OFF switch for the Photomic finder. To check battery power, perform the following: Pull out the lever just far enough to uncover the red meter ON index on the top of the camera; then, look within the finder to see if any of the LED exposure indicators are illuminated. If any of the indicators are lit, battery power is sufficient for proper operation. If none of the LEDs light, battery positioning should be checked; then, if the LEDs still fail to light, replace batteries.

Caution: Whenever the camera is stored, be sure that the filmadvance lever is set in the meter OFF position (i.e., flush to the body); failure to observe this precaution can result in total battery drain in a matter of days due to continuous illumination of one or more of the finder's LED indicators.

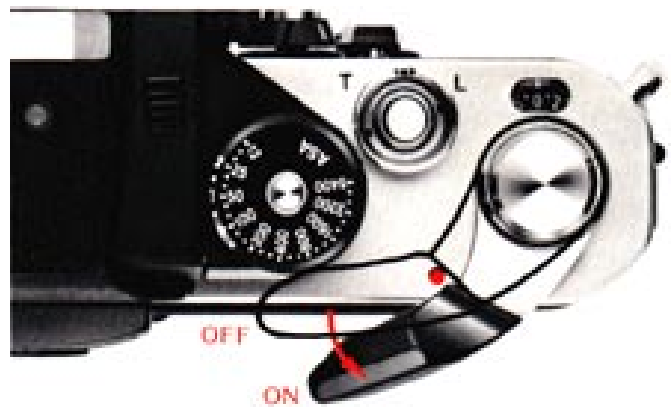

Loading the Film

Fold out the O/C key at the baseplate of the camera and turn it counterclockwise 180° until the arrow points to the “O” (open) mark and the camera back pops open. Pull up the rewind knob as far as it will go, and drop a standard film cartridge or a special Nikon reloadable cassette into the left-hand film chamber with the film leader aligned along the film guide rails.

After positioning the cartridge and film leader properly, push the rewind knob down to hold the cartridge in place and in-

sert the end of the film leader into any of the slots in the film take-up spool. If necessary, release the shutter and, then, stroke the film-advance lever slowly to make sure that the leader winds smoothly on the spool and that the film edge perforations engage with the film sprocket roller. When satisfied that the film is properly feeding and is traveling correctly along the film guide rails, close the camera back and return the O/C key to its normal storage position. (Also, see “Tips on Camera Care” on page 36.)

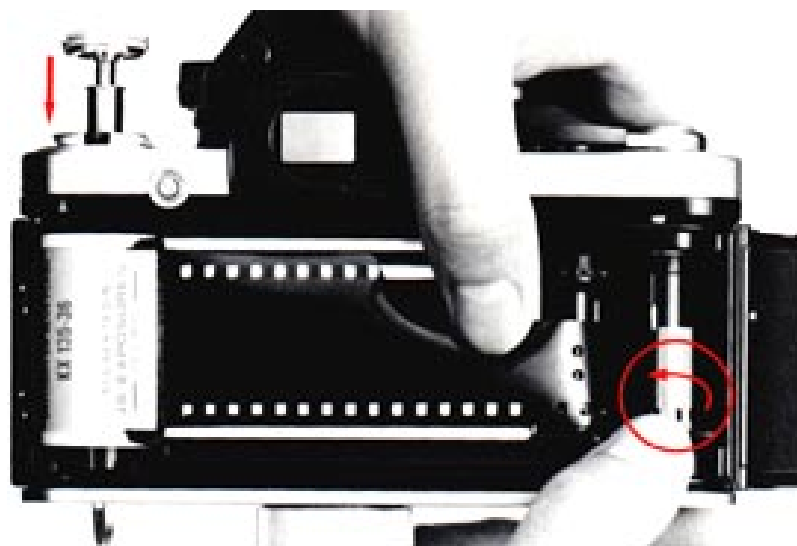
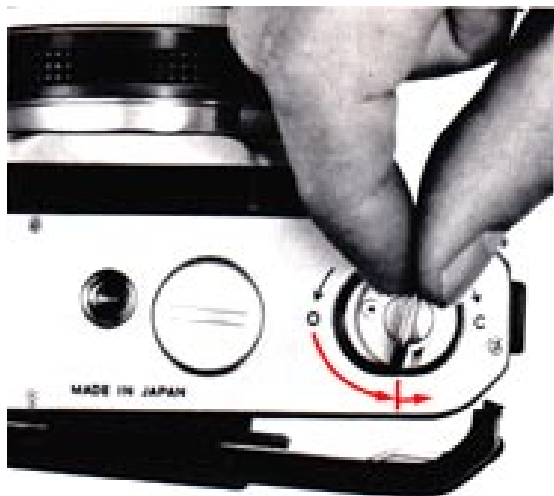

WWW.LENSINC.NET

PREPARATION FOR USE - continued

Prior to Shooting

Fold out the rewind crank and turn it gently in the direction of the engraved arrow until you feel a slight tension; this tension indicates that there is no more slack in the film cartridge. (Be sure not to rewind the film back into the cartridge.)

Advance the film and make two blank exposures to dispose of the initial portion of the film exposed during loading (for film advance operation, see page 11). While advancing the film, check that the rewind crank turns in the direction opposite the arrow. Crank rotation indicates that the film has been loaded properly and is being advanced. Then, fold the crank flat for storage.

After advancing the film two frames to dispose of the initial portion of the leader, the frame counter at the upper right of the camera will indicate "0"; now, advance the film one more frame to prepare the camera for taking the first exposure.



8

WWW.LENSINC.NET

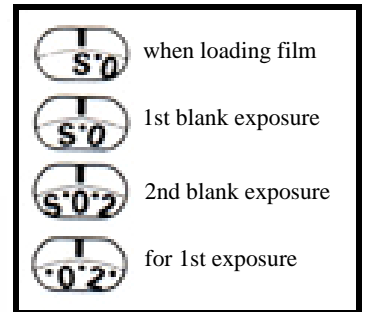

Memo Holder

A special holder is provided on the camera back for convenient storage of information pertinent to the photography. A piece of paper or the end-flap torn from the film carton can be inserted to serve as a reminder of the film type, film speed and number of exposures.

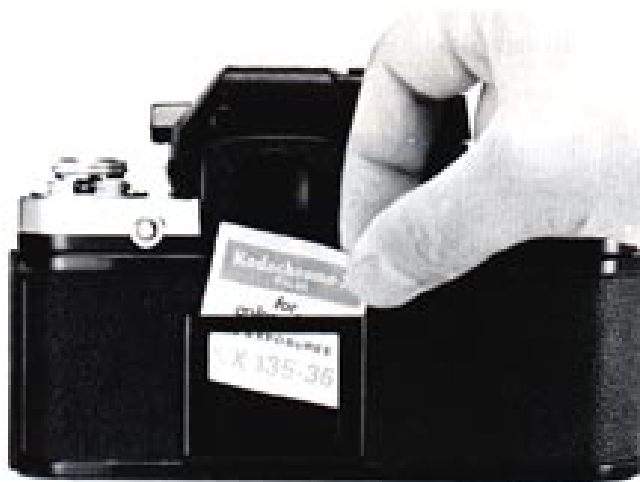

Setting the Film Speed

The camera's exposure meter must be adjusted to the speed of the film in use to ensure correct measurement; thus, a film-speed scale (ASA graduations) and an index ring are provided on the finder. To adjust, lift the milled ASA film-speed index ring and turn it until the red index triangle is aligned with the ASA value for the film in use. The meter is sensitive across the full range of from ASA 12 to ASA 6400. The film-speed dial has two dots between each pair of numbers for intermediate settings such as 64, 80, 125, etc.



WWW.LENSINC.NET

OPERATION OF CAMERA CONTROLS

Setting the Shutter Speed

The Nikon F2AS Photomic camera can be set to the desired shutter speed either before or after the shutter is wound. Speeds of from 1 second to 1/2000 second are set via the shutter-speed selector fitted on the finder; the selector is also provided with a “B” setting for longer time exposures. To set the shutter speed, turn the selector until the desired speed is aligned with the white dot; when aligned with settings of from 2 to 2000, the actual shutter speed will be a fractional value of from 1/2 second to 1/2000 second. The red line provided between the 1/60 sec. and 1/125 sec. settings indicates 1/80 second—the fastest shutter speed providing X synchronization for use with electronic flash units. When more precise settings are required, intermediate shutter speeds of from

1/80 sec. to 1/2000 sec. are usable. At the “B” setting, the shutter speed remains open as long as the shutter-release button is depressed. (See “Flash Synchronization” on page 34 for additional information on flash photography.)

Setting the Aperture

The ring fitted at the base of the lens adjusts the size of the aperture (or opening) in the iris diaphragm. To preset the lens aperture, turn the aperture ring until the desired f/number setting on the scale is aligned with the index mark provided on the lens. The iris diaphragm can also be set to intermediate apertures between the clickstop settings for more precise exposures.



Film-Advance Lever

The film-advance lever simultaneously advances the film, cocks the shutter and operates the frame counter. It also switches on the exposure meter in the Photomic finder. To advance the film, stroke the lever with the right thumb in a single stroke (or series of strokes) totaling only 120°. A built-in locking device prevents the shutter from being released unless it is fully cocked and the film advanced a full frame. At the completion of film advance, release the lever and it will return to the 20° standoff position ready for shutter release.

Note: Do not apply pressure to the film-advance lever while making an exposure.

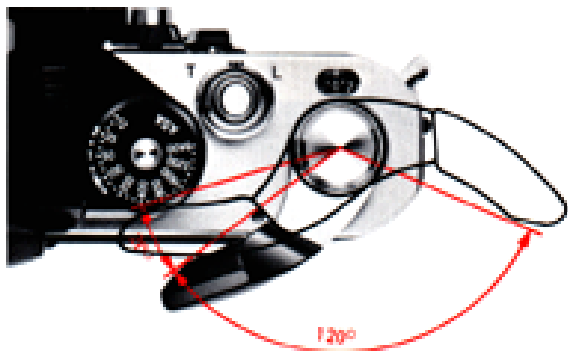

Frame Counter

The frame counter operates automatically to show how many frames have been exposed. When the camera back is opened for loading, the counter is reset to the “S” (start) position, two frames before “0”. Once the camera is loaded and the back closed, each film-advance/shutter-release sequence will cause the frame counter to advance one position until the maximum 20 or 36 frames have been exposed. The dial of the frame counter is calibrated with dots (for odd numbers) and figures (for even numbers), and with settings of “S,” “12,” “20” and “36” in red.

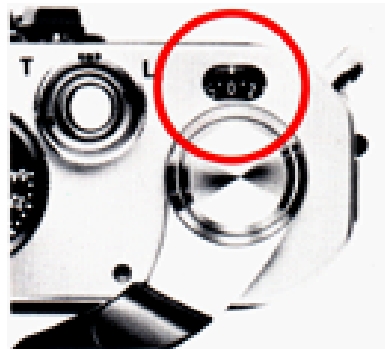

WWW.LENSINC.NET

OPERATION OF CAMERA CONTROLS - continued

T-L Fingerguard

The shutter-release button of the Nikon F2AS Photomic camera is fitted with a fingerguard that also doubles as the shutter operation mode selector. Set to the middle position, the fingerguard provides for normal shutter release via the shutter button. To lock the shutter to prevent accidental release, lift up and turn the fingerguard until the index dot aligns with the “L” (lock) marking. For time exposures preset via the camera’s built-in selftimer, lift up and turn the fingerguard until the index dot aligns with the “T” (time) marking. (See “Time Exposures” on page 25 for details.)

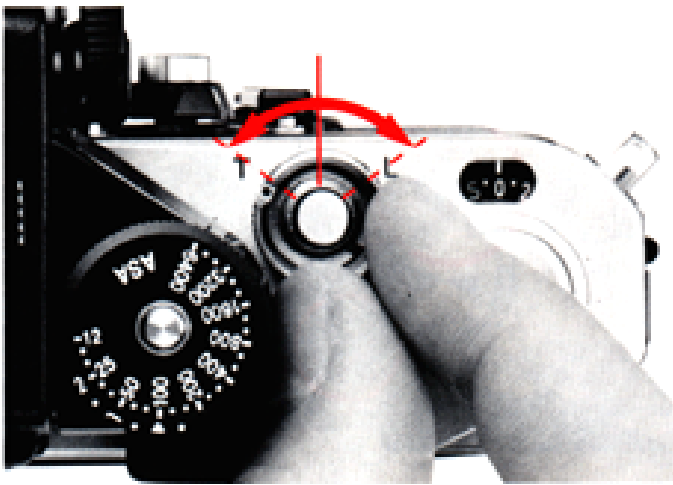

12

WWW.LENSINC.NET

Self-Timer

The built-in self-timer can be used to trip the shutter after a delay of from 2 to 10 seconds. The numbers marked on the timer scale indicate the delay in seconds. To take a picture using the self-timer to fire the camera, first set the aperture and shutter-speed controls, advance the film, and cock the self-timer by turning its lever downward until the index line (on the lever) aligns with the figure (on the scale) corresponding to the desired number of seconds delay; then, simply press the small button just above the timer to start the countdown, with shutter release occurring at the completion of the cycle. Note that the self-timer can be set either before or after advancing film; also, if you decide not to use the self-timer after setting it, simply use the shutter button in the normal way to make the next exposure and to release the self-timer for resetting to the off position. The self-timer may not be used at the “B” shutter-speed dial setting.



UNLOADING FILM

When the frame counter indicates that the last exposure has been made, or when the film-advance lever can no longer be stroked, the roll of film has been fully exposed and it should be removed.

To unload the camera, first press the rewind button on the camera baseplate; then, unfold the rewind crank, pull it up to the first detent position and turn it in the direction of the engraved arrow, using a smooth, even pressure. When no more tension is felt and the film advance indicator (the colored dot on the rewind button) stops rotating, the film leader has left the take-up spool and the camera back may be opened.

After opening the camera back, pull the rewind knob up as far as it will go and remove the film cartridge. Note that as the film advance lever is stroked for the next exposure, the rewind button will be released to engage the film-advance mechanism.

Caution: Be careful not to push the rewind button during film advance operation. Should this occur, the film transport will temporarily stop and double exposure may result.

Note: The camera back can be removed from the body by depressing the locking catch on the hinge. Removal of the camera back is necessary when the camera is used with any accessory back such as the 250 Magazine Back MF-1 or the Camera Back MF-3, both for motorized photography.



WWW.LENSINC.NET

HOLDING THE CAMERA

Camera shake is one of the most common causes of unsharp pictures, especially at slow shutter speeds. Learn to hold the camera correctly and practice steady shutter squeezing. The photos show the best ways to hold the camera for sharp pictures.

Wrap the fingers of the right hand around the camera body so that the index finger rests comfortably on the shutter-release button and the thumb fits between the camera body and the film-advance lever. Position the camera so that the eye looks through the center of the viewfinder. Cradle the camera in the left hand for additional support, with the left thumb and index finger grasping the focusing ring. From this basic stance, the camera can be properly supported and easily switched from horizontal to vertical format shooting. As a general rule, the slowest shutter speed you should use with the camera hand-held is equal to the reciprocal of the focal length of the lens in use (e.g., for a 500mm lens, use 1/500 sec.; for a 105mm lens, use 1/125 sec.). However, as the ability to hold the camera steady may vary with each individual, we recommend that you experiment. In general, the higher the selected shutter speed, the sharper the picture.



SHUTTER RELEASE OPERATION

For sharp pictures, correct shutter releasing is just as important as steady camera holding. After advancing the film to a fresh frame, the camera is set for shutter release via the button provided at the upper right. When taking the picture, hold the camera steady (as explained previously), relax and depress the button using a steady even pressure to release the camera's shutter—remember, a quick jab of the finger will cause camera movement and may result in a blurred photograph.

Operation via Cable Release

The shutter-release button can also be operated via a cable release or similar accessory attached via the threaded mount provided. With the cable release, operation is more vibration-free and often leads to sharper images under critical shooting situations such as photomicrography, time exposure, etc. To attach the cable release (Nikon-mount models AR-2, etc.) to the camera, screw the threaded cable connector onto the mount provided around the button. The shutter is then tripped by depressing the release plunger.

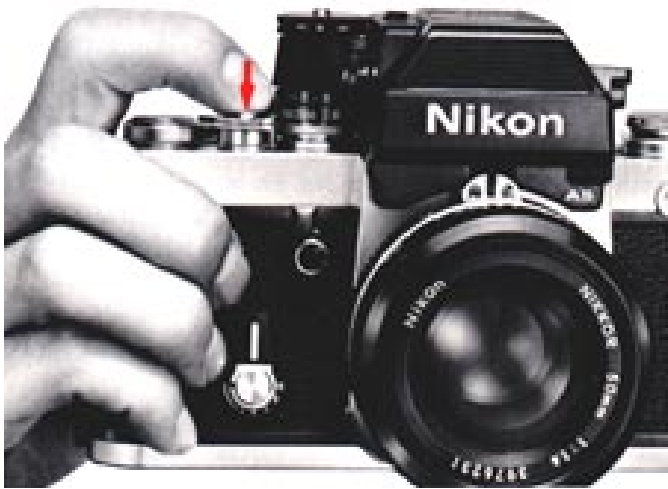

WWW.LENSINC.NET

FOCUSING

Focusing is done at full aperture with Nikkor lenses fitted with an automatic diaphragm. This technique provides the brightest possible images on the focusing screen for easy focusing and composing. It also minimizes depth of field so that the image snaps in and out of focus distinctly.

The Nikon Type K screen comes with the camera as standard equipment. To focus, turn the focusing ring on the lens until the two halves of the rangefinder image coincide to form a single, crisp image; when using the microprism ring, turn until the microprism pattern shifts to a sharp and crisp image. You can also focus on the matte field that surrounds the rangefinder/microprism central area.

The lens can also be prefocused using the distance scale engraved in both meters and feet on the lens barrel. Simply turn the focusing ring until the desired camera-to-subject distance (as measured or estimated) is lined up with the distance scale index on the lens barrel. This technique is useful for candid shots of elusive subjects when time does not permit through-the-lens focusing.



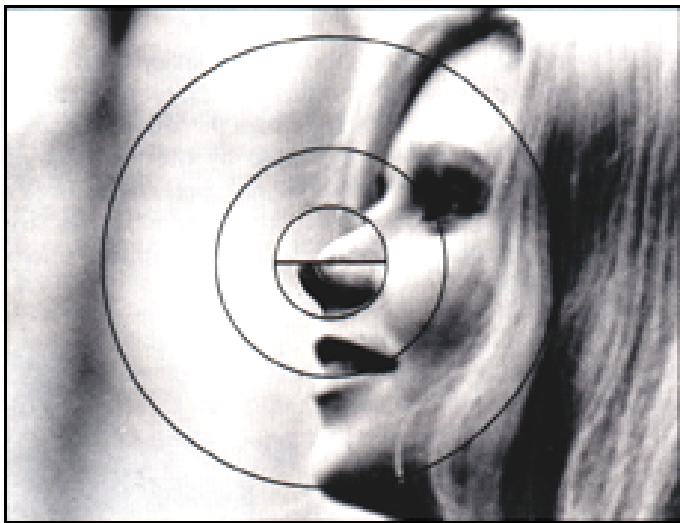

Out of focus

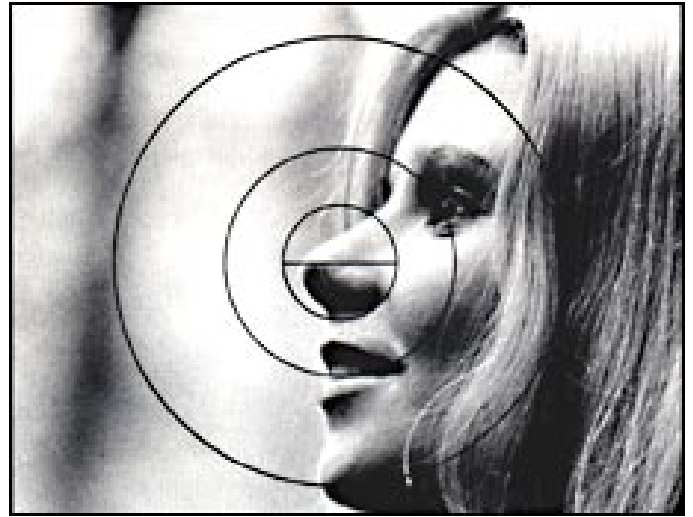

In focus

FOCUSING - continued

Infrared Photography

The plane of sharpest focus for infrared light is slightly more distant than its counterpart for visible light as seen through the camera's viewfinder. Thus, for sharpest focus in infrared photography, adjustments must be made.

To compensate for this shift in focus, first focus the image sharply through the viewfinder. Then, turn the focusing ring counterclockwise until the point focused is aligned with the red dot (or line) provided on the lens barrel. For example, in the picture below, the lens has been focused for infinity (no) infrared shooting. Note that when lenses having a focal length of 50mm or less are used stopped down to f/8 or below, no adjustment is necessary due to the large depth of field available.

Note: Some new optics using Nikon's Extra-low Dispersion (ED) glass, as well as reflex (catadioptric) lenses, do not require refocusing for infrared photography. Refer to individual lens instruction manuals for details.



Film-Plane Indicator

Under various precision shooting situations, such as close-up photography, it is often necessary to measure the film-to-subject distance to ensure the sharpest focus. The camera's film plane is indicated by the top edge of the figures making up the serial number at the upper left of the camera body. Note that these figures are 46.5mm from the front surface of the camera's lens mounting flange.

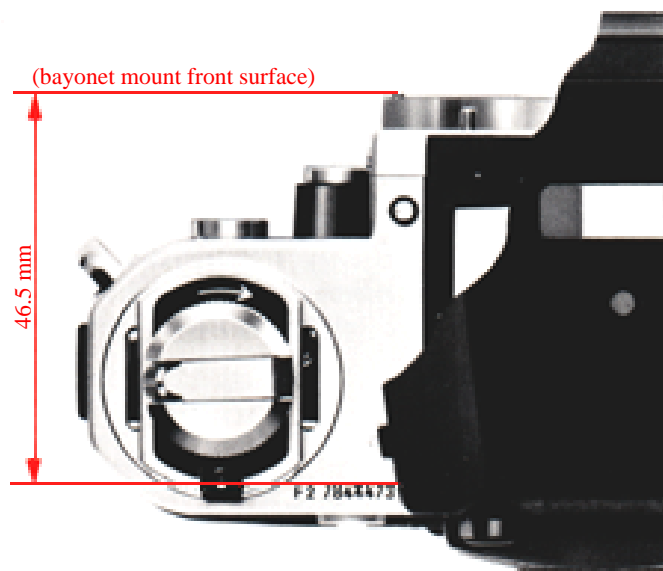

DEPTH OF FIELD

Depth of field refers to the zone of acceptable focus extending in front of, and behind, the plane of sharpest focus. Within this zone, image blur is negligible and everything may be considered as being in sharp focus. Three factors greatly influence the depth of field: the focal length of the lens in use, the camera-to-subject distance, and the taking aperture. The smaller the aperture and the shorter the focal length of the lens, the greater the depth of field. Also, the closer the subject, the shallower the depth of field. These three factors can operate independently or in conjunction with one another, with any one factor capable of partially canceling the effects of the other. Thus, by careful selection and use, the photographer can exercise wide creative control over the final picture.

Depth-of-Field Preview Button

As most Nikkor lenses are operated at full aperture for ease of focusing, visualization of the depth of field at the shooting aperture may be difficult. Thus, the camera's depth-of-field preview button often can come in handy. The depth-of-field preview button lets you check (or "preview") the zone of sharpness at any time before (or after) shooting. Simply by depressing the button, the lens is stopped down to the preselected aperture to allow you to see how much background and foreground is in or out of focus.



WWW.LENSINC.NET

DEPTH OF FIELD - continued

Depth-of-Field Indicators

Depth of field can be read directly from the distance scale in meters or feet with the aid of the color-coded depth-of-field indicators engraved on the lens barrel. Each pair of colored lines on either side of the central distance scale index line corresponds to f/numbers of the same color on the aperture scale. To find the depth of field at a particular aperture, first focus the lens on the subject while looking through the viewfinder. Then check the numbers on the distance scale to determine the zone of focus for the aperture in use. The three photos shown clearly depict the changing depth of field; with the photo to the right, the field is shallow at the f/4 setting, while the photo at the far right shows a depth of field extending from approximately 2.7m (9 ft) to infinity (∞)

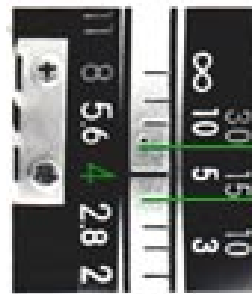

Lens at f/4: Shallow depth of field centered on the main subject.

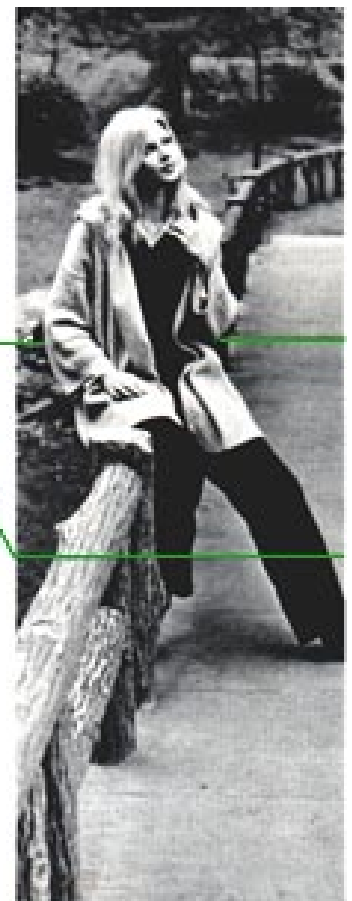

EXPOSURE MEASUREMENT

The exposure meter of the F2AS Photomic finder utilizes Nikon's through-the-lens center-weighted exposure measurement at full aperture. The meter reads the light over the entire focusing screen but favors the central 12mm-diameter area, while taking the entire area into consideration. This allows you to make precise readings of the selected subject area, and results in more balanced overall exposures.

Determining Exposure

The finder has three LED exposure indicators visible within the viewfield (“+” for overexposure, “o” for correct exposure, and “—” for underexposure); thus, the metering system is capable of providing easy-to-read exposure information in five steps, and even at extremely low-light levels. Additionally, the selected shutter speed and lens aperture settings are visible for maximum ease of operation for setting the desired exposure.

To determine the correct exposure with the Nikon F2AS: Switch ON the meter by moving the film-advance lever to the 20° standoff position; with this action, one of the LED indicators will light, indicating overexposure, correct exposure or underexposure. If the plus (+) indicator lights, increase the shutter speed or decrease the aperture until the center (o) indicator just comes on and the (+) turns off; if the minus (-) indicator is lit, decrease the shutter speed or increase the aperture until the center indicator lights. When two LEDs light simultaneously (i.e., + and a, or—and o), the exposure setting is within 1-stop of correct exposure; thus, be sure to adjust the aperture setting slowly to get only the correct “center” (a) exposure. Values for the five settings of the LEDs are described in the figure on this page.

-	Underexposure by more than 1 stop
o -	Underexposure by 1/5 to 1 stop
o	Correct exposure
+ o	Overexposure by 1/5 to 1 stop
+	Overexposure by more than 1 stop



WWW.LENSINC.NET

EXPOSURE MEASUREMENT - continued

Exposure Control

The amount of light reaching the film plane is determined by a combination of the lens aperture and the shutter speed. Since the two are interrelated, different combinations will give the same exposure. A 1-step change in the shutter speed, or a 1-stop change in the aperture setting, will either halve or double the exposure. For example, a shutter speed of 1/125 second passes twice as much light as a setting of 1/250 second, and only half as much light as a speed of 1/60 second; for an aperture setting of f/11, twice as much light as f/16, and half as much as f/8, is passed. This feature characterizes the operation throughout the available range of shutter speeds and aperture settings. With this in mind, it's easy to see that if a correct exposure for a scene is 1/125 at f/11, then 1/60 at f/16 or 1/250 at f/8 will be equally acceptable.

The best combination for your needs will depend on the results desired. Use fast shutter speeds to freeze motion, or use slow speeds to produce deliberate and creative blur. Small apertures give greater depth of field, while large apertures restrict sharp focus to the main subject. The creative selection of both speeds and apertures will greatly enhance your photography.

Metering Range

If the center "correct exposure" LED fails to illuminate, even after all possible lens-aperture/shutter-speed combinations have been tried, then the available light is too bright or too dim for the meter's range. To correct this situation, several measures may be taken, as follows: Switch to a new film (either higher or lower ASA) that more closely matches the available light; mount a neutral density filter on the lens to decrease the light reaching the film plane; or use artificial lighting (i.e., an electronic flash unit) to increase subject illumination. Remember, too, that the lens in use can greatly influence suitability for bright or dim shooting. For example, a 50mm f/1.4 lens (with ASA 100 film) couples from EV—2 (f/1.4 at 8 seconds) to EV 17 (f/8 at 1/2000 second) for excellent low-light performance; on the other hand, a 200mm f/4 lens proves more usable at bright-light levels, coupling (with ASA 100 film) from EV 1 (f/4 at 8 seconds) to EV 20 (f/22 at 1/2000). Thus, choose the lens carefully to match the existing lighting conditions.

Extreme Low-Light Metering

The meter built into the Nikon F2AS camera is capable of metering low-light levels requiring slow shutter speeds of up to 10 seconds. To meter at low-light levels, perform the following: Set the lens' aperture ring to the desired aperture setting, and the shutter-speed selector to "B"; then, depress and hold the shutter-speed dial lock and turn the selector until the center LED exposure indicator (o) illuminates to indicate correct exposure. Having set the selector, read off the number on the extralong exposure scale and set the camera's self-timer for the indicated value; then, set the T-L fingerguard to "T" and depress the shutter button to make the exposure. When performing low-light metering, be sure to block the entry of stray light into the viewfinder by closing the eye-piece shutter or by continuously viewing through the finder. (Refer to accompanying photos for details.)

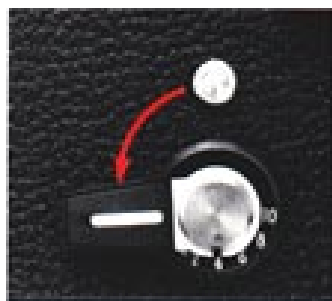

Time Exposures

The Nikon F2AS Photomicofferstime exposure shooting convenience via built-in controls which enable long exposures without the need for accessory equipment. To make an exposure longer than 10 seconds, set the shutter-speed selector to "B" and turn the T-L fingerguard to "T" as described in "Extra-long Exposures." Advance the film and press the shutter-release button to open the shutter. As long as the fingerguard remains set to "T," the shutter will remain open. When returning the fingerguard to the normal center position to close the shutter, be careful not to move or shake the camera, as a blurred image may result.

Note: Operation with a Nikon cable release (see page 15) can also provide for time exposures via the release's built-in locking function. For operation in these cases, leave the T L fingerguard in the center position and trigger the camera with the shutter speed dial set to the "B" setting.



WWW.LENSINC.NET

EXPOSURE MEASUREMENT - continued

Eyepiece Shutter Operation

The camera's Photomic finder is fitted with an eyepiece shutter for special unmanned shooting situations (e.g., remote control, automated shooting with motor drive and aperture control unit) requiring protection against the entry of stray light through the viewfinder eyepiece. To close the shutter, simply turn the eyepiece shutter control 60° clockwise; as the shutter closes, the internal LEDs are deactivated and the external "correct exposure" indicator is switched on for metering operation from atop the finder. To set the camera for proper exposure using the external LED indicator, simply adjust the aperture ring and/or the shutter-speed selector until the LED just glows; once the LED comes on, the camera is set for correct exposure.

In addition to its use for low-light metering or for unmanned photography, the eyepiece shutter comes in handy to ensure correct exposure measurement in critical shooting situations (e.g., photomicrography) or for protection against the entry of bright light into the viewfinder during daylight shooting.

High-Contrast Lighting Situations

When there are substantial brightness differences between the main subject and the background, unimportant bright spots or dark spots can adversely influence the finder reading, and thus the final exposure. To prevent under- or overexposure of the main subject under these shooting conditions, some corrective action must be taken to ensure proper exposure of the main subject. Fortunately, the finder's center-weighted TTL metering action simplifies adjustments, making for quicker camera operation and more accurate final results.

To compensate for an excessively bright or dark background, target the main subject in the center of the focusing screen while performing metering; this action ensures that the main emphasis of the meter reading will be on the chosen subject. Then, after completing aperture and shutter speed adjustments, recompose to the desired picture composition and make the exposure without readjusting the camera controls. For example, when shooting landscapes, it is often advisable to aim the camera slightly downward during exposure measurement to eliminate the effects of a bright expanse of sky; without such compensation, the landscape may appear underexposed in the final print. Also, for backlit subjects, it may be necessary to move closer to the subject to ensure a proper reading.



- Metering with a bright area in the center will cause underexposure of the main subject.

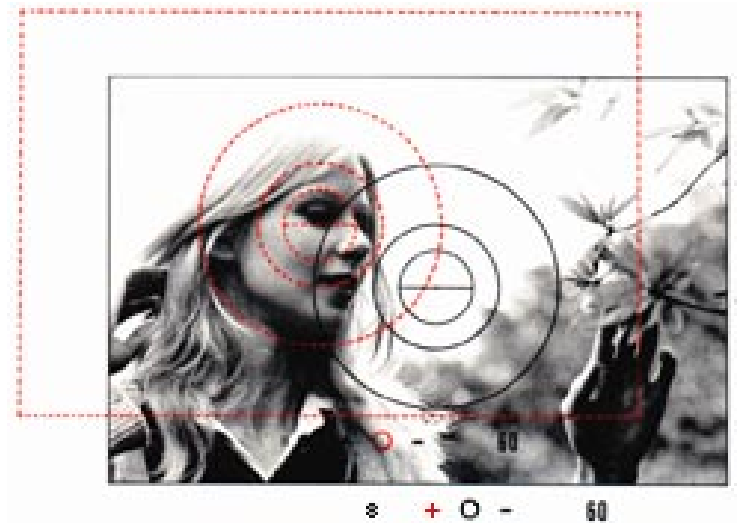

- For correct exposure, first measure the main subject; then, recompose and shoot.

STOP-DOWN EPOSURE MEASUREMENT

With some Nikkor lenses, full-aperture exposure measurement is not possible, either because the lens has no automatic diaphragm, or because the lens does not couple with the finder's meter; with certain accessories, too, lens/finder coupling is not possible, thus, preventing fullaperture measurement. However, the camera's Photomic meter can still be used for exposure measurement via the stop-down method. Before mounting the lens (or accessory) on the camera body, push the meter coupling lever up and to the right; with this action, the lever will remain locked up for stop-down exposure measurement (to release the lever after removing the lens/accessory, push the release to the right as described in "Coupling Lever Lock/Release Operation" on page 39). After setting the finder, mount the lens or lens/accessory combination on the camera, switch on the meter by moving the film-advance lever to the standoff position, and then set the controls for correct exposure as follows:

For automatic diaphragm lenses with no coupling ridge, set the camera to the desired shutter speed; then, depress the depth-of-field preview button to stop down the lens diaphragm and, while holding the button depressed, adjust the aperture ring until the center LED indicator comes on. Be sure to release the depth-of-field button prior to making the exposure.



For fixed-aperture lenses, such as Reflex-Nikkor lenses, simply adjust the shutter-speed selector until the center LED indicator comes on. For convenience, shutter speeds can be set at intermediate settings in the 1/80 sec. to 1/2000 sec. speed range for precise exposures. If the meter indicates continuous overexposure, use a neutral density filter or slower film. If continuous underexposure is indicated, supplementary lighting or a faster film is necessary. This technique is also suitable for photography using a telescope or microscope.

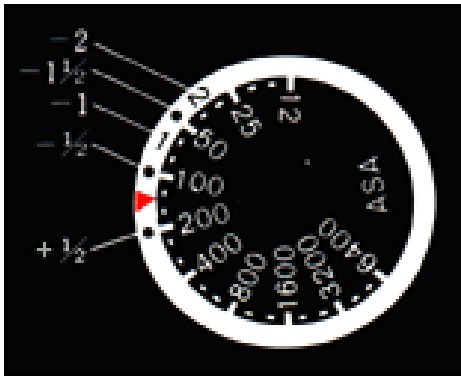

For bellows units, extension rings and preset lenses, set the camera to the desired shutter speed; then, stop down the lens manually until the center LED indicator comes on. Pre-set-type lenses include PC-Nikkor lenses.

EXPOSURE COMPENSATION ADJUSTMENT



Adjustments for Focusing Screens

Light transmission properties vary somewhat with focusing screen type, thus occasionally requiring exposure correction to compensate for the combined effects of the lens/screen combination in use. The numbers listed in various blocks of the table on the opposite page denote the amount of correction necessary in f/stops. To adjust the camera's finder for the indicated f/stop correction, lift and turn the ASA film-speed index ring until the ASA value for the film in use is aligned with the appropriate mark engraved on the ring. In the example figure shown, ASA 100 is aligned with the $-1/2$ mark to provide the correction required when using the Type C screen with the Nikon F2AS Photomic camera and the Fisheye-Nikkor 6mm f/2.8 lens, as indicated in the table. (When "O" is indicated in the table, no compensation is required.)

-
-  = Exposure measurement via full-aperture method.
 -  = Exposure measurement via stop-down method.
 -  = Exposure measurement not possible; lens/screen combination permits only focusing operation.

Blank space indicates lens/screen combination cannot be used.

Lens	Screens	A/L	B	C	D	E	G1	G2	G3	G4	H1	H2	H3	H4	J	K/P	M	R
Fisheye	6mm F2.8	0	0	-1/2	-1/2	0	-1/2	0			0	0			0	0		0
	8mm F2.8	0	0	-1/2	-1/2	0	-1/2	0			0	0	0		0	0		0
	16mm F3.5	0	0			0	-1/2				0				0	0		0
Wideangle	13mm F5.6	0	0			0		-1				-1/2			0	0		0
	15mm F5.6	0	0			0		-1				-1/2			0	0		0
	18mm F4	0	0			0	-11/2				-1				0	0		0
	20mm F4	0	0			0	-1				-1/2				0	0		0
	24mm F2	0	0			0		0			+1/2	0			0	0		0
	24mm F2.8	0	0			0		0			+1/2	0			0	0		0
	28mm F2	0	0			0	+1/2	+1/2			+1/2	+1/2			0	0		0
	28mm F2.8	0	0			0	0				+1/2				0	0		0
	28mm F3.5	0	0			0	-1/2	0			0	0			0	0		0
	35mm F1.4	0	0			0		+1/2			+1/2	+1/2			0	0		0
	35mm F2	0	0			0	+1/2	+1/2			+1/2	+1/2			0	0		0
	35mm F2.8	0	0			0	0				+1/2	0			0	0		0
Normal	50mm F1.4	0	0			0		+1/2			+1/2	+1/2			0	0		0
	50mm F2	0	0			0	+1/2	+1/2			+1/2	+1/2			0	0		0
	55mm F1.2	0	0			0		0			0				0	0		0
Telephoto	85mm F1.8	0	0			0		+1/2			+1/2	+1/2			0	0		0
	85mm F2	0	0			0		+1/2			+1/2	+1/2			0	0		0
	105mm F2.5	0	0			0		0			+1/2	+1/2			0	0		0
	135mm F2	0	0	0	0	0		+1/2			+1/2	+1/2			0	0		0
	135mm F2.8	0	0	0	0	0		0			+1/2	+1/2			0	0		0
	135mm F3.5	0	0			0		-1			0				0	0		0
	180mm F2.8	0	0	0	0	0			0		0	0	0	0	0	0		0
	200mm F4	0	0	0	0	0		-1 1/2				-1/2			0	0		0
	300mm F4.5	0	0	0	0	0			-1 1/2			-2	-1	-1	0	0		0
	ED 300mm F4.5	0	0	0	0	0						-1 1/2	-1/2	-1/2	0	0		0
	400mm F4.5	0	0	0	0	0									0	0		0
	*ED 400mm F3.5	0	0	0	0	0			-1	-1/2			0	-1/2	0	0		0
	ED 400mm F5.6	0	0	0	0	0									0	0		0
	600mm F5.6	0	0	0	0	0									0	0		0
	*ED 600mm F5.6	0	0	0	0	0									0	0		0
	Ed 600mm F5.6	0	0	0	0	0									0	0		0
	800mm F8	0	0	0	0	0									0	0		0
	ED 800mm F8	0	0	0	0	0									0	0		0
	1200mm F11	0	0	0	0	0									0	0		0
	ED1200mm F11	0	0	0	0	0									0	0		0
Zoom	28-45mm F4.5	0	0			0					-1/2				0	0		0
	43-86mm F3.5	0	0			0		-1				-1/2			0	0		0
	50-300mm F4.5	0	0			0			-2				-1		0	0		0
	ED50-300mm F4.5	0	0			0			-1			-1 1/2	-1/2		0	0		0
	80-200mm F4.5	0	0			0			-1			-1 1/2	0		0	0		0
	ED180-600mm F8	0	0	0	0	0									0	0		0
	200-600mm F9.5	0	0	0	0	0									0	0		0
ED360-1200mm F11	0	0	0	0	0									0	0		0	
PC	28mm F4	0	0			0									0	0		0
	35mm F2.8	0	0			0									0	0		0
GN	45mm F2.8	0	0			0	0				0			0	0		0	
Noct	58mm F1.2	0	0			0		0			0	0		0	0		0	
Micro	55mm F3.5	0	0			0								0	0		0	
	105mm F4	0	0			0								0	0		0	
Medical	200mm F5.6	0	0			0								0	0		0	
Reflex	500mm F8	0	0	0	0	0								0	0		0	
Telephoto	1000mm F11	0	0	0	0	0								0	0		0	
	2000mm F11	0	0	0	0	0								0	0		0	

* Internal focusing type

EXPOSURE COMPENSATION ADJUSTMENT-continued

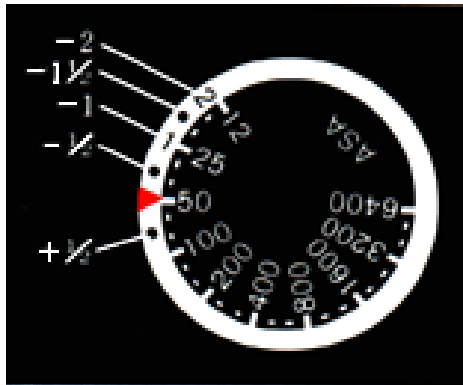

Adjustments for Film Compensation

Some exposure correction may be necessary when certain types of films are used for copying or photomicrography applications; the amount of correction required, however, will depend on the type of film and the specific application. The following table lists the exposure corrections in Estops required for various film/shooting requirements. Compensation is possible by adjusting the shutter speed or the aperture by the indicated amount; also, compensation is possible by adjusting the ASA film-speed index ring. In the example shown, the index ring is set so that the red mark is aligned with ASA 50; this setting is the correct position to achieve a one-stop increase in exposure (three scale graduations equal one stop) as required when performing photomicrography (see table) using ASA 100 Panchromatic film.

Original Type of film	Repro-copying & slide-copying			Photo- microg- raphy
	B&W color photo	Letters or figures on light background	Letters or figures on dark background	
Panchromatic film for general use	No compensa- tion necessary	+1 1/2 stops	- 1/2 stop	+1 stop

MULTIPLE EXPOSURES

Intentional multiple exposures for creative effects can be made with the Nikon F2AS Photomic camera. To take a multiple exposure, perform the following: Make the initial exposure, depress and hold the rewind button on the camera's baseplate, and stroke the film-advance lever to cock the shutter for the next exposure on the same frame; for each additional exposure on the frame, repeat the same procedure. At the completion of multiple exposure operation, stroke the filmadvance lever once more to release the rewind button, cover the lens and make one blank exposure, and then resume normal operation. Note that during multiple exposure operation, the camera's shutter speed can be changed to any setting for the desired shooting effect. Also, throughout the multiple exposure operation, the camera's frame counter will remain at the same setting as long as the rewind button is held depressed while stroking the filmadvance lever.



MIRROR LOCKUP

The reflex mirror must be locked up when using either the Fisheye-Nikkor 6mm f/5.6 or the OP Fisheye-Nikkor 10mm f/5.6 lenses, since their rear elements protrude into the camera body and interfere with mirror movement. Locking up the mirror is also necessary when shooting with a motor drive unit at its top speed setting. To lock up the mirror, depress and hold the depth-offield button and turn the mirror lock-up lever downward until the white dot is aligned with the white index line. The mirror will remain in the up position until the lever is returned to the normal position.



WWW.LENSINC.NET

FLASH SYNCHRONIZATION

The Nikon F2AS Photomic camera is designed to synchronize with most types of flashbulbs at almost all shutter speeds and with electronic flash at speeds to 1/80 second. The table below shows which shutter speeds may be used with different types of flashbulbs.

Flash-bulb	Shutter speed (sec.)														
	2000	1000	500	250	125	x(80)	60	30	15	8	4	2	1	B	
FP	Green	Green	Green	Green	Green	Red	Red	Green	Green	Green	Green	Green	Green	Green	Green
M	Red	Red	Red	Red	Green	Red	Red	Green	Green	Green	Green	Green	Green	Green	Green
MF	Red	Red	Red	Red	Red	Red	Red	Green	Green	Green	Green	Green	Green	Green	Green
Speed-light	Red	Red	Red	Red	Red	Green	Green	Green	Green	Green	Green	Green	Green	Green	Green

Synchronized
 Cannot be used

No special adapters are necessary when using the Nikon F2AS Photomic camera with the Flash Unit BC-7 or with the Speedlight Unit SB-2 or SB-5. For other Nikon flash units with ISO-type hot-shoe contacts, mounting on the camera is via the Flash Unit Coupler AS-1; with the AS-1, no sync cord is required, as it provides full connection via the camera's hotshoe contact.

Caution: When the reflex mirror is locked in the up position, the shutter will not synchronize with flashbulbs at speeds faster than 1/80 second.



READY-LIGHT

The camera's Photomic finder has a ready-light built in for use with Nikon Speedlight Units. This unique feature provides for greater ease of operation during flash photography, as the photographer need not remove his eye from the eyepiece to check if the Speedlight unit is ready for the next exposure; this built-in lamp lets the photographer know the condition of the flash (either "ready" when on, or "not ready" when off) at all times even while viewing. (For additional information, see the instruction manual supplied with the Speedlight.)



FINDER ILLUMINATOR

When shooting under low-light levels, the finder's shutter speed indicator (located just below the viewfinder image) is often difficult to read. To solve this problem, the Photomic finder is fitted with a finder illuminator. To operate, slide the illuminator switch at the top of the finder toward the rear of the camera; with this action, the shutter speed setting will glow red.



WWW.LENSINC.NET

TIPS ON CAMERA CARE

Good camera care is primarily common-sense care. Treat your Nikon F2AS Photomic camera as you would any other precision optical instrument and it will provide you years of trouble-free service. Although ruggedly constructed, your camera may be damaged by shock, heat, water or misuse. By observing the following tips, you will be assured of the longest possible service life.

- Fingerprints or dust on lens/prism surfaces will make viewing uncomfortable, and will generally contribute to a deterioration of optical performance. Clean lens surfaces often using a quality lens tissue or a soft lens brush; stubborn smudges should be wiped with lens tissue moistened with methyl alcohol or a quality lens cleaner. Never clean lens surfaces using cloth, paper towels, ordinary tissue, or any other material that might scratch the lens surface; also, use cleaning fluids sparingly to prevent seepage, and resulting damage to mechanical components.
- When interchanging lenses, finders, etc., your camera is susceptible to the entry of dust or other contaminants. It is a good idea to clean moving body parts frequently to prevent the build-up of dust; here, a lens brush and blower will come in very handy. When blowing out the interior of the camera, however, avoid contact with the shutter curtains, as they are easily damaged. Also, wipe the outer body surfaces using a silicone-impregnated cleaning cloth to remove fingerprints, etc. quickly and easily. (Note that a silicone impregnated cleaning cloth should never be used to clean the lens surfaces.)
- When exposed to sudden temperature changes or high humidity, condensation may form on the lens surfaces. After using in these situations, always dry the

the camera thoroughly (and slowly) at room temperature and, then, store in a cool, dry location. Remember that failure to dry out the camera may result in the growth of fungus on lens surfaces—a condition that will render your camera useless.

- Should your camera be accidentally dropped on the floor or in water, take it to your dealer immediately for servicing. Thorough servicing can be guaranteed only at an authorized dealer.
- always store the camera in an ever-ready case or compartment case when not in use. And be sure that the lens cap is attached to the lens. Do not leave film in the camera for a long period of time, and never store the camera with the shutter or self-timer cocked.
- Never lubricate any part of the camera. Lubrication should be left to an authorized service center. Prior to a holiday trip or important shooting assignment, test your camera (including changing batteries, if necessary) for proper operation.
- Observe normal battery handling procedures for maximum performance at all times. Be sure to: Clean batteries periodically (wiping with a rough cloth will remove residues that might otherwise impede performance); install batteries properly, checking for proper polarity; remove batteries when not using the equipment for an extended period; change weak batteries promptly to prevent leakage within the camera; store unused batteries properly (in a cool, dry location) to maximize service life; dispose of batteries properly (do not burn); and keep out of the reach of children. For details regarding battery performance, refer to the original manufacturer.

CHANGING THE LENS

To remove the lens from the camera body, press the lens release button and, holding the button depressed, twist the lens clockwise as far as it will go. With this action, the lens will come loose and can be lifted out.

To mount a lens fitted with a meter coupling ridge, perform the following: Check that the finder's meter coupling lever is released (see "Coupling Lever Lock/Release Operation" on page 39 for details); position the lens in the camera's lens mounting flange so that the mounting indexes on the lens and camera body are aligned; and, then, twist the lens counterclockwise until it clicks and locks into place. These

steps provide for full mounting of the lens, while simultaneously indexing the lens's maximum aperture setting to the camera's Photomic finder.

To mount a lens not fitted with a meter coupling ridge, first lock the meter coupling lever in the up position (again, see "Coupling Lever Lock/Release Operation" for details). Then mount the lens and lock it into position as explained previously. For operation with lenses not fitted with a meter coupling ridge, stop-down measurement (as described on page 28) is required.



Coupling Lever Lock/Release Operation

The camera's Photomic finder is fitted with a meter Coupling lever that provides for coupling between the finder's metering circuit and the lens' meter coupling ridge. When the camera body is used with lenses offering automatic maximum aperture indexing, the lever remains in the normal position. However, when the camera body is used with lenses and/or accessories not provided with this feature, the lever must be locked up to permit exposure measurement via the stop-down method. To lock up the lever prior to mounting the lens, simply push upward and to the right until the lever clicks and locks into position. To release the lever for operation with a lens or accessory capable of automatic maximum aperture indexing, simply slide the coupling lever release (located just above the lever) to the right until the lever returns to its normal lowered position; then, mount the lens as explained previously.



CHANGING THE VIEWFINDER

In addition to the F2AS Photomic finder included with the camera, four other interchangeable viewfinders are available. To remove the F2AS Photomic finder to mount one of the other units, press the finder release lever inward and rotate toward the front (this action releases the mounting clamps); then, depress the finder release button at the rear of the camera body and lift the finder out of the camera.

To attach a viewfinder other than a Photomic-type model, set it in position and press down firmly until it clicks and locks into place on the camera.

To attach a Photomic-type model (including the F2AS Photomic finder included with the camera), first set the aperture ring of the lens (if mounted) to the maximum aperture setting; then, gently position the finder on the camera and firmly press it down until it clicks and locks into place (see Photo A). Once in place, turn the finder's shutter-speed selector left or right until it engages with the camera's shutter-speed dial and the two can be turned in tandem (see Photo B). Note that if the finder is an AI-type model fitted with a meter coupling lever, the lever should be released prior to mounting the finder on the camera body (see "Coupling Lever Lock/Release Operation" on page 39 for details).



(A)

(B)



CHANGING THE FOCUSING SCREEN

Nineteen different types of focusing screens are available for use with the Nikon F2AS Photomic camera, each designed to meet specific focusing requirements. The Nikon Type K screen comes with the camera as standard equipment.

To change the focusing screen, first remove the finder as Described on the preceding page. Then, turn the camera body upside-down and press the finder release button a second time to release the screen.

To mount a screen, simply place it in position with the flat side facing downward and the “Nikon” mark to the front of the camera. Then, press the finder release button and the screen will drop into place.

Caution: When changing the focusing screen, be careful not to touch the optical surfaces. When removing the screen, it is advisable to place a clean, dry cloth over the palm of the hand to catch the screen as it drops free of the camera.



CHANGING THE FOCUSING SCREEN-continued

Focusing Screen Selector Guide

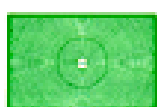
**Type A L**

Type A: Matte Fresnel field with 3mm-circular split-image rangefinder spot and 12mm-circle. Rapid and accurate focusing. Excellent for general photography.

Type L: Same as Type A screen but with split-image rangefinder line at a 45° angle. Best for subjects with horizontal lines

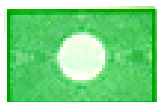

Type B: Matte Fresnel field with 12mm-p fine ground matte focusing spot in the center. Good for general photography, especially with long lenses.

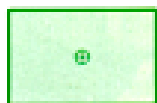

Type C: Fine-ground matte field with 4mm clear spot and cross hair. For photomicrography, astrophotography and other high-magnification applications, and for parallax focusing on aerial images



Type D: Overall fine-ground matte field. For specialized close-up photography and for use with long lenses

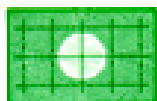

Type E: Matte Fresnel field with Ammo fine ground matte spot and etched horizontal and vertical lines. Ideal for architectural photography.



Type G: Clear Fresnel field with extra-bright 12mm-microprism focusing spot for viewing and focusing in poor light. Four models (G1-4) are available corresponding to specific focal length lenses. Depth of field cannot be observed.

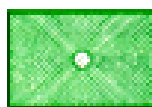

Type H: Clear Fresnel field with microprism focusing pattern over the entire screen area. Permits rapid focusing on any part of the screen with optimum edge-to-edge brightness in poor light. Available in four models (H1-H4) corresponding to particular focal length lenses

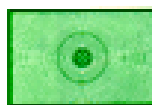

Type J: Matte Fresnel field with central microprism focusing spot and 1 Emmy circle. Good for general photography.

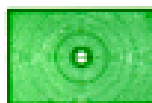

Type K: Combination of Type A and J screens. Matte Fresnel field with 3mm-split-image rangefinder spot surrounded by 1mm-wide microprism doughnut. Rapid and accurate focusing for subjects with both straight lines and ill-defined contours. Suitable for general photography.

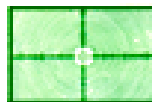

Type M: Fine ground Fresnel field with 5.5mm clear spot and double cross hair for use in parallax focusing on aerial image, plus millimeter scales for calculation of individual magnification of objects or for measuring objects. Brilliant image in dim light. Suitable for close-ups, photomicrography and other high-magnification applications.

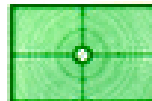

Type P: Same as Type K but with split-image rangefinder line at a 45° angle and etched horizontal and vertical lines as an aid to composition. Rapid and accurate focusing for subject with horizontal or vertical lines or ill-defined contours. Suitable for general photography.

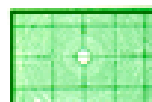

Type R: Same as Type A but with rangefinder prisms of sloping surfaces at a smaller angle and horizontal and vertical lines to aid proper composition. Works best with lenses having maximum aperture of from f/3.5 to f/5.6

Focusing Screen Selector Chart

- = Excellent
- = Acceptable

The image is brilliant from edge to edge, but the central rangefinder, micro-prism or cross-hair area is dim. Focus on the surrounding matte area.

= Acceptable
Slight vignetting or moire phenomenon (in the case of the microprism) affects the screen image. But the image on film shows no traces of this.

= Acceptable
Incompatible with any lens having a maximum aperture larger than f/2.8 since this decreases the efficiency and accuracy of the screen rangefinder. The in-focus image in the central spot may prove to be slightly out of focus on film. Focus on the surrounding matte area.

Lens	Screens	A/L	B	C	D	E	G1	G2	G3	G4	H1	H2	H3	H4	J	K/P	M	R		
Fisheye	6mm F2.8																			
	8mm F2.8																			
	16mm F3.5																			
	13mm F5.6																			
Wideangle	15mm F5.6																			
	18mm F4																			
	20mm F4																			
	24mm F2																			
	24mm F2.8																			
	28mm F2																			
	28mm F2.8																			
	28mm F3.5																			
	35mm F1.4																			
	35mm F2																			
Normal	35mm F2.8																			
	50mm F1.4																			
	50mm F2																			
	55mm F1.2																			
Telephoto	85mm F1.8																			
	85mm F2																			
	105mm F2.5																			
	135mm F2																			
	135mm F2.8																			
	135mm F3.5																			
	180mm F2.8																			
	200mm F4																			
	300mm F4.5																			
	ED 300mm F4.5																			
	400mm F4.5																			
	*ED 400mm F3.5																			
	ED 400mm F5.6																			
	600mm F5.6																			
*ED 600mm F5.6																				
Ed 600mm F5.6																				
Zoom	800mm F8																			
	ED 800mm F8																			
	1200mm F11																			
	ED1200mm F11																			
	28-45mm F4.5																			
	43-86mm F3.5																			
	50-300mm F4.5																			
	ED50-300mm F4.5																			
	80-200mm F4.5																			
	ED180-600mm F8																			
PC	200-600mm F9.5																			
	ED360-1200mm F11																			
	28mm F4																			
	35mm F2.8																			
GN	45mm F2.8																			
	58mm F1.2																			
Noct	35mm F3.5																			
	105mm F4																			
Micro	200mm F5.6																			
	500mm F8																			
Medical	1000mm F11																			
	2000mm F11																			
Reflex	1000mm F11																			
	2000mm F11																			

Caution: The rear surface of the screen is made of acryl resin. Special care should be taken to protect it from scratching or excessive pressure.

WWW.LENSINC.NET

ACCESSORIES

EE Aperture Control Attachment DS-12

Specially designed for operation with the Nikon F2AS Photomic camera and AI-type Nikkor lenses, the EE Aperture Control Attachment DS-12 brings the F2 user the convenience of automatic aperture control. With the DS-12, the photographer is free to concentrate fully on the subject while the attachment's built-in servo mechanism is automatically adjusting the aperture setting as necessary for perfectly exposed photographs under even changing lighting conditions. Power for DS-12 operation is via any of three optional power sources.

Lens Hoods

The use of a lens hood is recommended at all times to prevent extraneous light from striking the lens surface and causing flare or ghost, and to protect the lens against damage. Nikon lens hoods come in four types, depending on the lens: screw-in, snap-on, slip-in and built-in. They are calculated precisely for each focal-length Nikkor lens to provide maximum protection against stray light.

To attach or remove the snap-on hood, first depress the spring latch—which is marked with an arrow—and slide it in the direction of the arrow. The hood will also fit directly over a screw-in filter, so both can be used on a lens at the same time. When not in use, the snap-on hood can be reversed for storage on the lens, and the lens and its hood can be stored together in the ever-ready case.



Filters

Nikon filters are made of optical glass, ground and polished so that both surfaces are optically flat and parallel. Nikkor lenses and Nikon filters are made for each other. For best results, use Nikon filters on Nikkor lenses. The filters are available in both screw-in and series mounts, depending on the lens.

Except for the R60, no Nikon filter requires exposure compensation when used with the Nikon F2AS Photomic. When using the R60 filter under tungsten light, increase the exposure by one f-stop more than indicated by the exposure meter.

Note: If you wish to leave a filter on the lens to protect the lens against accidental damage, the use of the L37 or L37C filter is recommended.



WWW.LENSINC.NET

Finder Eyecup

The soft rubber finder eyecup screws directly onto the finder eyepiece to prevent extraneous light from entering the viewfinder.

When using an eyepiece correction lens with a finder eyecup, it is recommended to use the Nikkormat type eyecup. First, fit the lens into the eyecup in advance. Then screw the assembly onto the finder eyepiece.

Eyepiece Correction Lenses

The nine eyepiece correction lenses are designed to permit nearsighted and farsighted users to view and focus without their glasses. Available in—2, -3, -4,—S. 0, +0.5, +1, +2 and +3 diopters, each representing the combined dioptery of the lens and the finder. Simply screw into the finder eyepiece.

Camera Cases

Available in hard, semi-soft or soft (pouch) construction, Nikon camera cases offer excellent protection for your camera body and mounted lens. Various case sizes are available to accommodate most Nikkor lenses mounted on the camera body.

FEATURES/SPECIFICATIONS

Type of camera: 35mm single-lens reflex (SLR)

Picture format: 24mm x 36mm (35mm~film format)

Lens mount: Nikon F mount (bayonet type)

Lenses available: Nikkor 50mm f/1.4, f/2 or 55mm f/1.2 as standard; more than 50 Nikkor lenses in all

Shutter: Horizontal-travel focal-plane shutter; speeds of from 1 to 1/2000 second and "B"; speeds of from 2 to 10 seconds available via built-in self-timer; intermediate settings possible between 1/80 and 1/2000 second; shutter release via shutter button or self-timer

Flash synchronization: Automatic selection as shutter speed is set; hot-shoe contact with built-in safety switch provided; one threaded PC terminal provided for off-camera flash operation

Synchronization range: 1/2000~1/125 sec., 1/30~1 sec. and "B" for FP bulbs; 1/30~1 sec. and "B" for M and MF bulbs; 1/80~1 sec. and "B" for electronic flash

Accessory shoe: Special Nikon-type built into body; fitted with hot-shoe contact and electric safety switch which turns on contact as flash unit is mounted

Viewfinder: Interchangeable eyelevel pentaprism type with built-in through-the-lens (TTL) exposure meter (model DP-12); selected aperture and shutter speed indicated below viewfield; eyepiece shutter provided

Focusing screen: Matte Fresnel field with central splitimage rangefinder surrounded by microprism ring; 12mm diameter reference circle defines area of meter center-weighting; Nikon Type K screen

Reflex mirror: Instant-return type; lockup lever provided.

Exposure metering: Through-the-lens, center-weighted, full-aperture measurement employing two silicon photodiodes (SPD) for fast response; exposure correctly set by adjusting for illumination of single central lightemitting diode (LED) indicator; meter cross-coupled with both diaphragm and shutter speed controls and automatically indexed as lens is mounted; powered by two 1.5V silver-oxide batteries

Metering range: EV—2 ~ EV 17 (i.e., f/1.4 at 8 sec. ~ f/8 at 1/2000 sec.) with 50mm f/1.4 lens and ASA 100

Film speed scale: Setting provided for ASA 12 ~ 6400

Lens diaphragm coupling: Built-in meter coupling lever for Nikkor lenses capable of automatic maximum aperture indexing; meter/diaphragm coupling of from f/1.2 to f/32 provided

Film winding: Via single-stroke lever with 120° winding angle and 20° stand-off angle; lever also serves as meter ON/OFF switch

Frame counter: Shows number of frames exposed (additive type); automatically resets to "S" (two frames before "0") when camera back is opened

Film rewinding: Manual via film rewind crank; coupling provided on baseplate for rewind via motor drive

Depth-of-field preview: Via button provided on front of camera

Body finish: Satin-chrome and semi-gloss black

Weight: 840g (body only)

Dimensions: 152.5mm x 102mm x 64.5mm